



SL-101 Series

SLIDE SWITCH



Specification:								
8(3)A	250VAC	T125		6.5A 13A	250VAC 125VAC	T125		
10(2)A	250VAC	T85						
12(2)A	250VAC	T85						
				8A 16A	250VAC 125VAC	T125		

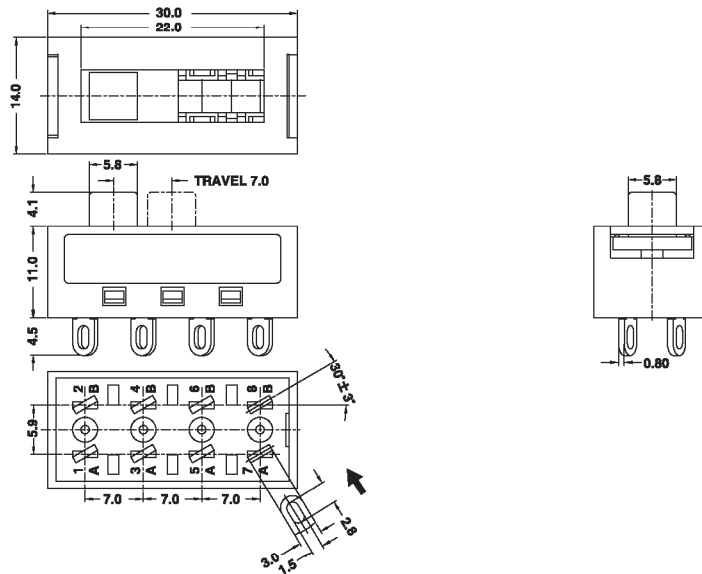

SL - 101 —

23		M		8		S	
Circuit	Ref: Base Dimension	Current	Knob Type	Terminal Type	Internal Use Only		
11 1P1T		G 8(3)A 250VAC 13A 125VAC M 10(2)A 250VAC 13A 125VAC L 10(2)A 250VAC 16A 125VAC	1	S			
21 2P1T			2	S1			
12 1P2T			3	S2			
22 2P2T		4	P1				
13 1P3T		5	H				
23 2P3T		7					
14 1P4T		8					
24 2P4T							
15 1P5T							
25 2P5T							